

Internal Antennas for Digital TV Receiver

E. Palantei, Andani A., M. Baharuddin, N.K. Nauman, S. Syarif, M. Anshar, NNRA Mokobombang, A. Suyuti, Z. Muslimin, Z. Zainuddin, Indrabayu A., F. Mayasari, A. Ejah US, S. Kanata and Z.B. Hasanuddin
TTI, Electrical Engineering Department, UNHAS Makassar, Indonesia;
E-mail: elyas_palantei@unhas.ac.id

L. Ramos E., N. Zain, and D. Mariana
PT. Hewlett Packard Indonesia and
Himpunan Mahasiswa Teknik Elektro (HME)
Universitas Hasanuddin (UNHAS)
Makassar, Indonesia
E-mail: lompo_amos@hp.com;
lompo_amos@yahoo.co.id; nurmavantizain@yahoo.com

Abstract—Various types of internal antennas suitable for digital TV receiver have been investigated. These include rectangular plate loop structure, $1/2\lambda$ monopole, and L-dipole. Evaluations of the internal antennas were done, numerically and experimentally, to obtain some electrical properties such as S_{11} , $VSWR$, gain and radiation pattern. All the fabricated antennas are incorporated inside the TV receiver body. This allows more flexible, moveable, compact, and inexpensive construction of digital TV in the future.

Keywords -- internal antennas; digital TV; rectangular plate loop; L-dipole; linear wire dipole

I. INTRODUCTION

Conventionally since a long time ago a Yagi antenna has been utilized together with a TV receiver system to capture the illumination of the electromagnetic waves energy broadcasted from a TV broadcasting station. This antenna type has become more popular among the people living both in urban or rural. The popularity of Yagi antenna is not only due to the excellent electrical characteristics such as gain and directivity but also other benefits including easiness in the process of design/construction/fabrication, installation and maintenance. Yagi antenna is also very easy to find and inexpensive in the local market [1-2].

Apart from the many advantages and ease of practical application, this type of antenna has some limitations in terms of the flexibility of use. As for instance in Indonesia, an outdoor Yagi antenna is usually installed on the roof of the house using a high pillar. If there are 2 to 3 sets of TV receiver device in one house then it will take more towers to install them. The negative impact raised in the environmental issue. The beauty scene degraded due to the crowded arrangement of the antenna installation. The atmosphere like that is very disturbing view. Meanwhile, as the position of the TV receiver changed in the building the configuration of cable connection must also be reinstalled.

Nowadays, there is a Yagi antenna for indoor applications widely available in the market place which can be connected to the TV receiver to replace the outdoor one. But in terms of size and model it would require the proper arrangement of the room/space so that the quality of signal reception can not be interfered due to the mobility of moving objects/people and the influence of interference from electronic devices in the vicinity

[2]. This arrangement should also consider the beauty aspect in the room. For applications in other communication systems to access various DVB services such as from mobile phones, laptops/notebooks and PDAs the newest research and innovations concerning the construction of the internal antenna are very important to conduct. The antenna design must fits perfectly integrated inside a communication device. Some research activities to discover a new internal antenna have been published [3-7].

In contrast to the results of previous research publications, this scientific paper work describes the results of investigations on a number of the internal antenna specifically designed to be integrated with digital TV receiver. Technical specification design models tailored to the standard television in Indonesia, especially to suitable for the future digital TV applications.

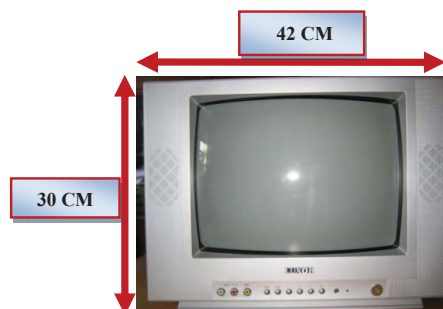

(a). TV receiver model

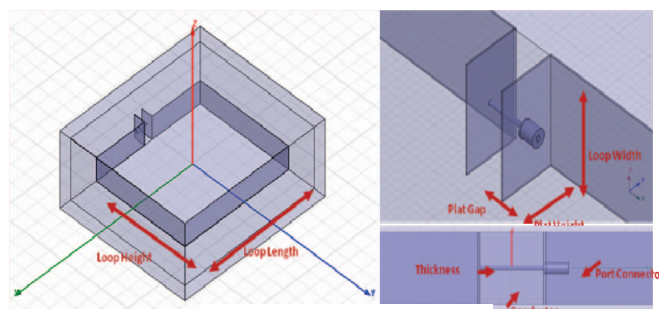

(b). Rectangular Plate Loop

Fig.1: The constructed rectangular plate internal loop antenna for TV receiver, (a) TV receiver model, (b). Rectangular plate loop

II. CONSTRUCTED INTERNAL ANTENNAS

There are three types of internal antennas that have been designed, fabricated and tested through both the numerical and experimental activities, namely the rectangular plate loop, $1/2\lambda$ monopole, and L-dipole. The systematic explanations for each type of antenna are described in the following sub-sections.

A. Rectangular Plate Loop Antenna

A typical model of the constructed internal antenna is shown in Fig.1. The rectangular plate loop antenna was designed using the aluminum material with $\epsilon_r = 1$. The dimension of the loop antenna parts are tabulated in Table 1. In actual application, the physical size and the antenna model were created to fit the inner cover body of the TV receiver model as depicted in Fig.1 (a). The proper distance separation from the metal plate loop antenna to the surrounding electronic parts such as CRT, RF parts and other components must be set up to maintain the high quality of antenna construction and very excellent digital TV receiver performance.

TABLE I. THE SIZE OF THE LOOP ANTENNA ELEMENTS

Antenna Elements	Unit (cm)
Plate Width	6
Loop Height	29
Loop Length	40
Loop Width	6
Plate Height	4
Plate Gap	4
Thickness	0.1
Radius of Conductor	0.15

B. A $1/2\lambda$ Monopole

The prototype of internal antenna developed from a $1/2\lambda$ aluminum tube is illustrated in Fig.2. In fact, the antenna can be positioned at one edge of the inside cover body of TV receiver, left, right or up side corner. The antenna was constructed from the aluminum material with $\epsilon_r = 1$. Underneath of one end of the aluminum tube an isolator PVC ($\epsilon_r = 3,4$ and dielectric loss tangent 0,001) was placed. This isolator has two functions i.e. to place the RF connector and as a holder to hold the monopole antenna while installed inside the TV body. The radius of the aluminum tube is 10 mm. The optimized length was 170 mm.

C. L-Dipole

Basically, the L-dipole antenna was constructed from the conventional linear wire dipole by configuring one pole of two aluminum tubes in such away they are perpendicular one to another. However, one pole of aluminum tube was made little shorter in the length dimension. The circuit diagram and the fabricated visualization of the L-dipole are shown in Fig.3 (a) and (b), respectively. Each part of two aluminum tubes are connected each other through SMA connector positioned at the centre of PVC holder (see Fig.3 (b)). The physical dimension of each pole/tube is optimised to 19.5 cm (the longer) and 9.8 cm (the shorter), respectively. The same electrical properties of materials i.e. aluminium and PVC were used as a $1/2\lambda$ monopole above.

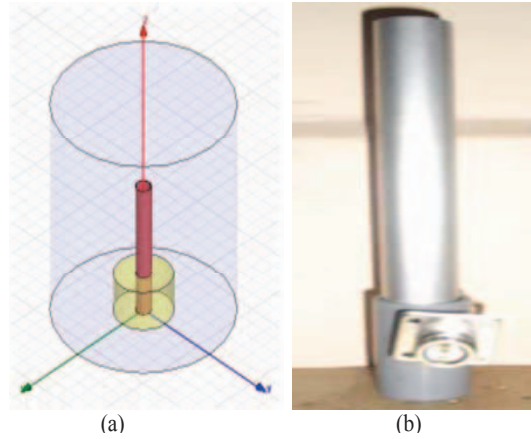

Fig.2: $1/2\lambda$ Monopole: (a) Simulated, (b) Fabricated

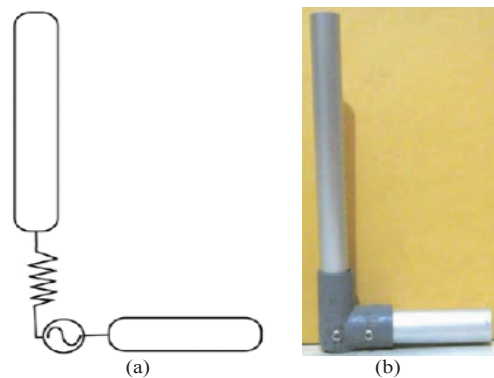

Fig.3: L-Dipole: (a) Circuit diagram, (b) Fabricated

III. PERFORMANCE EVALUATIONS

Some electrical properties of the internal antennas were outlined and evaluated in this section including the reflection coefficient, VSWR, pattern property, gain and the quality of signal reception. These were obtained through the numerical computation using HFSS11 and the practical measurement in an unisolated room utilizing VNA E5071C, the antenna trainer ED-3200C and other electronic devices.

A. Reflection Coefficients and VSWR

The visualization of the reflection coefficients of the three kinds of internal antennas are described in Figs.4, 5, and 6, respectively. Each antenna design has a different of frequency operation. The rectangular plate loop has a good resonance in the range from 620 to 760 MHz, numerically, and from 640 to 1.4 GHz, experimentally. This is a very good practical bandwidth which is more than 700 MHz.

Practically, the designed monopole antenna can perform well at the broad frequency range from 1110 to 2887 MHz. In this frequency range VSWR is 2:1. Meanwhile, the L-dipole antenna has very excellent bandwidth ranging from 375 to 3297 MHz. VSWR of this antenna is 2:1.

The research project was supported from R&D Produk Telekomunikasi Grant funded through DIPA 2010, General Directorate of Post and Telecommunication, Ministry of Communication and Information, Republic of Indonesia; SK SEKJEN POSTEL No.11/DJPT.5/KOMINFO/IV/2010

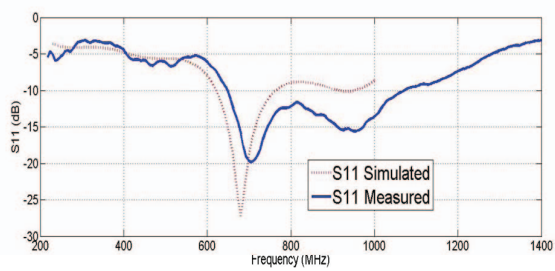

Fig.4: The reflection coefficient of rectangular plate loop

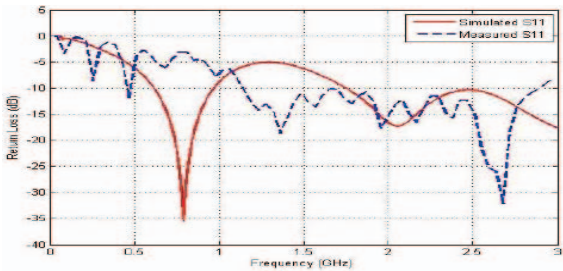

Fig.5: The reflection coefficient of $1/2\lambda$ monopole

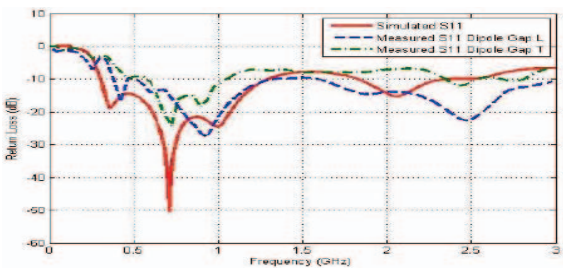

Fig.6: The reflection coefficient of L-dipole

B. Pattern Properties

The pattern properties of three types of internal antennas are depicted in Figs.7, 8, and 9. The three internal antennas are very good radiator and sensitive receptor devices to transmit and to receive the electromagnetic wave energy in the vicinity. The difference of maximum and minimum power level at each pattern is larger than 40 dBi. All of the antennas can illuminate, approximately, the same power level to all directions.

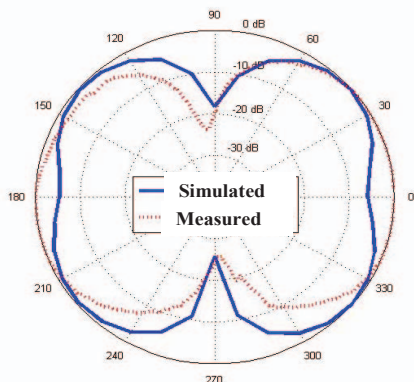
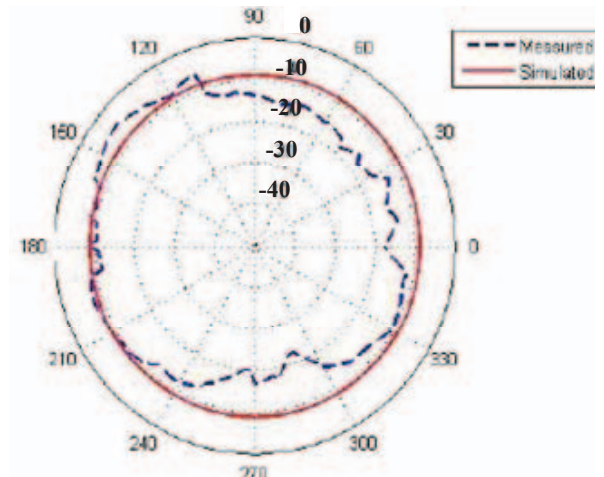
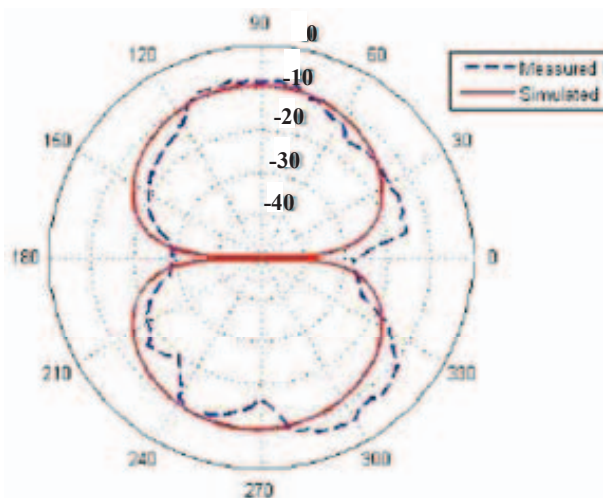

Fig.7: Pattern Properties of rectangular plate loop (Elevation)



(a)



(b)

Fig. 8: Radiation Pattern of $1/2\lambda$ monopole: (a) Azimuthal, (b) Elevation

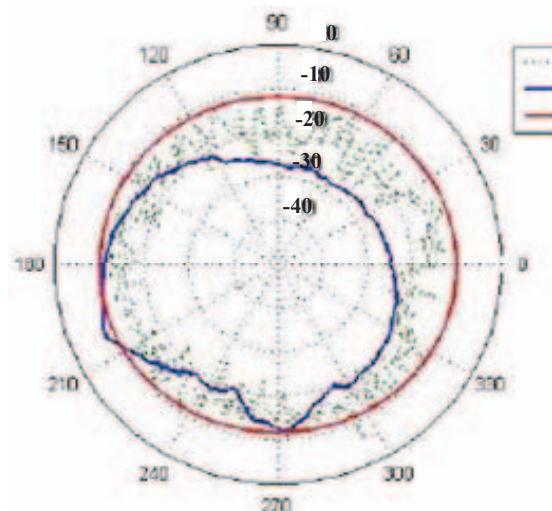

Fig. 9: Radiation Pattern (Azimuthal): the red line-simulated; the blue line-measured L-dipole 1-gap; the green dotted line-measured L-dipole 2-gap

C. Gain

The simulated and measured gains of three kinds of internal antennas are tabulated in Table II. Even though, both gains are small however they are comparable larger than the gain published in some open literatures mentioned in [8], i.e. in average greater than 2 dB. In actual situation, these antennas meet the standard specification for DVB system in the future.

TABLE II. GAIN OF THREE DIFFERENT TYPES OF INTERNAL ANTENNAS

Type of Antenna	Gain (dB)		
	Simulated (HPBW)	Measured (HPBW)	Measured (Friis)
Rectangular Plate Loop	3.8	3.73	3.54
1/2 λ Monopole	4.78	7.7	3.32
L-Dipole	4.8	2.64	2.22

D. Signal Quality of TV Reception

To perform as a real internal antenna the three constructed antennas were incorporated inside a TV trainer and tested in Telecommunication, Radio and Microwave Laboratory which is located in Department of Electrical Engineering, Universitas Hasanuddin. All the antennas have performed well while integrated with the real TV peripheral. In this section only the test results using L-dipole antenna will be discussed in detailed.

As shown in Fig.10 the deployment of L-dipole internal antenna exhibits the good results on TV screen. As the dipole antenna of 5 x 5 mm gap separation (1st-gap) between poles is integrated together with electronic components inside the TV body a TV trainer is able to capture 12 local channels including Makassar TV, ANTV, Indosiar, MNC TV, RCTI, SCTV, Metro TV, Trans 7, Global TV, Trans TV, Reuters, and the National TVRI / TVRI Makassar. A TV channel is unable to be captured only the signal from Fajar TV.



Fig.10: The quality of TV trainer reception using an L-dipole antenna

Unlike the above case the installation of the dipole with the gap 30 mm x 30 mm (2nd-gap), a TV trainer is capable to capture only 11 local TV channels namely ANTV, Indosiar, MNC TV, RCTI, SCTV, Metro TV, Trans 7, Global TV, Trans TV, Reuters, and the National TVRI / TVRI Makassar. The rests of the local TV Channels that can not be captured well are Makassar TV and Fajar TV. There are several possible factors that influenced the quality of the signal reception. One main factor affected this problem is the resonance frequency of the

constructed antennas which slightly excludes the operation frequency range of the most commercial Digital TV (from 575 MHz to 1050 MHz). Another factor might be in the poor power transmission illuminated from the local TV broadcasting station or the TV repeater stations.

IV. CONCLUSIONS

A number of internal antennas including the rectangular plate loop structure, 1/2 λ monopole and L-dipole have been constructed and examined through the numerical computation and the practical measurement. The designed antennas have an excellent performance in terms of a broad operation frequency, very sensitive RF power reception and relatively good gain suitable for digital TV receiver.

ACKNOWLEDGMENT

The authors would like to thanks to the Directorate of Standardization, the General Directorate of Post and Telecommunication, Ministry of Communication and Information for supporting the sufficient R&D grant to conduct various internal antennas researches and for providing a number of high quality equipments to allow us to perform some testing of the constructed antennas. The authors would also extend their sincere thanks to anyone who contributed to the establishment of the MoU between CWMA, Griffith School of Engineering, Griffith University, Australia and Telematics Laboratory, Department of Electrical Engineering, Universitas Hasanuddin (UNHAS), Indonesia. The collaboration is mainly focusing in R&D and education activities.

REFERENCES

- [1] Balanis, C.A. 2005. "Antena Theory Analysis and Design". *Textbook* 3rd Edition. New Jersey : John Wiley and Sons.
- [2] E. Palantei and D.V. Thiel, "Yagi-Uda Antenna Human Proximity Effects on the Link Budget at 300 MHz," *IEEE APS Symposium Digest*, Nort Charleston, South Carolina, 1-5 June 2009.
- [3] J. Holopainen, J. Villanen, M. Kyrö, C. Icheln, and P. Vainikainen," Antenna for Handheld DVB Terminal," *IEEE APS Symposium Digest*, 2006.
- [4] H. Suzuki, I. Ohba, T. Minemura, and T. Amano, "Frequency Tunable Antennas for Mobile Phone for Terrestrial Digital TV Broadcasting Reception," *IEEE APS Symposium Digest*, 2006.
- [5] J. Kim, G. Kim, W. Seong, and J. Choi, "A Tunable Internal Antenna with An Epsilon Negative Zeroth Order Resonator for DVB-H Service," *IEEE Transactions on Antennas and Propagation*, Vol. 57, No.12, December 2009.
- [6] J.T. Aberle, S.H. Oh, D.T. Auckland, and S. D. Rogers, "Reconfigurable Antennas for Portable Wireless Device," *IEEE Antennas and Propagation Magazine*, Vol. 45, No.6, December 2003.
- [7] E. Palantei, D.V. Thiel, and S.G. O'Keefe, "Rectangular Patch with Parasitic Folded Dipoles: A Reconfigurable Antenna," *Proceedings of IEEE iWAT2008 Conference*, Chiba, Japan, 4-6 March.
- [8] E. Palantei, Andani A., M. Baharuddin, N.K. Nauman, S. Syarif, M. Anshar, NNRA Mokobombang, A. Suyuti, Z. Muslimin, Z. Zainuddin, Indrabayu A., F. Mayasari, A. Ejah US, S. Kanata and Z.B. Hasanuddin, "Rancang Bangun Antena Internal untuk Perangkat Penerima TV Digital," *R&D Produk Telekomunikasi Progress Reports*, the Directorate of Standardization, the General Directorate of Post and Telecommunication, Ministry of Communication and Information, Republic of Indonesia.